



KLER

ESTD 1973



"I know how to make good furniture. Having almost 50 years of experience speaks for itself. Fashions come and go, but the sense of taste and elegance remains unflagging. For good."

– P. Kler, the Founder of the Company

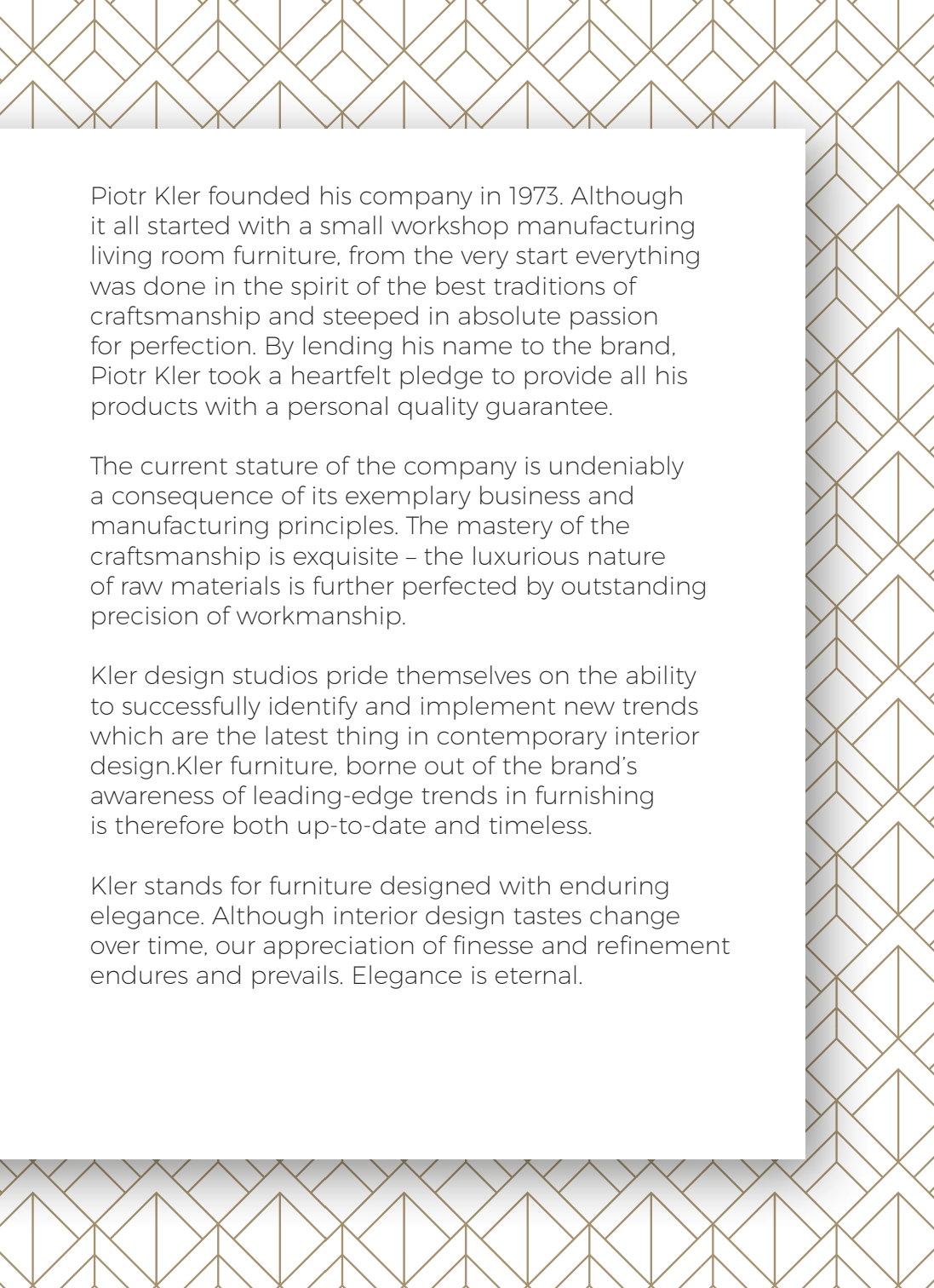

Piotr Kler founded his company in 1973. Although it all started with a small workshop manufacturing living room furniture, from the very start everything was done in the spirit of the best traditions of craftsmanship and steeped in absolute passion for perfection. By lending his name to the brand, Piotr Kler took a heartfelt pledge to provide all his products with a personal quality guarantee.

The current stature of the company is undeniably a consequence of its exemplary business and manufacturing principles. The mastery of the craftsmanship is exquisite – the luxurious nature of raw materials is further perfected by outstanding precision of workmanship.

Kler design studios pride themselves on the ability to successfully identify and implement new trends which are the latest thing in contemporary interior design. Kler furniture, borne out of the brand's awareness of leading-edge trends in furnishing is therefore both up-to-date and timeless.

Kler stands for furniture designed with enduring elegance. Although interior design tastes change over time, our appreciation of finesse and refinement endures and prevails. Elegance is eternal.





sofas and
armchairs

Idillio



KLER SOFAS AND
ARMCHAIRS



KLER

Libretto



KLER SOFAS AND
ARMCHAIRS



KLER

Libretto



KLER SOFAS AND
ARMCHAIRS



KLER

Salterio



KLER SOFAS AND
ARMCHAIRS



KLER

KLER SOFAS AND
ARMCHAIRS



Sonore



Sonore



KLER SOFAS AND
ARMCHAIRS



KLER

Scaletta



KLER SOFAS AND
ARMCHAIRS



KLER

Solfeggio



KLER SOFAS AND
ARMCHAIRS



KLER

Gondoliere



KLER SOFAS AND
ARMCHAIRS



KLER

KLER SOFAS AND
ARMCHAIRS



Gondoliere



Vocalizzo



KLER SOFAS AND
ARMCHAIRS



KLER

Vocalizzo



KLER SOFAS AND
ARMCHAIRS



KLER

KLER SOFAS AND
ARMCHAIRS



Opera



Opera



KLER SOFAS AND
ARMCHAIRS



KLER

Diva



KLER SOFAS AND
ARMCHAIRS



KLER

Maestro



KLER SOFAS AND
ARMCHAIRS



KLER

Bolero



KLER SOFAS AND
ARMCHAIRS



KLER

KLER SOFAS AND
ARMCHAIRS



Carmen



Concerto



KLER SOFAS AND
ARMCHAIRS



KLER

Sincope



KLER SOFAS AND
ARMCHAIRS



KLER

Soprano



KLER SOFAS AND
ARMCHAIRS



KLER

Soprano



KLER SOFAS AND
ARMCHAIRS



KLER

Riposta



KLER SOFAS AND
ARMCHAIRS



KLER

KLER SOFAS AND
ARMCHAIRS



Fuga



Fuga



KLER SOFAS AND
ARMCHAIRS



KLER

Capriccio



KLER SOFAS AND
ARMCHAIRS



KLER



Piotr **KLER**
ATELIER

Piotr Kler Atelier

is Piotr Kler's master studio – a place where the dreams of investors and designers come true.

The studio processes orders which are truly unique, unprecedented and unconventional. It develops original designs, elaborated as single items which are specifically tailored to meet the needs of a special and unusual place.

They constitute bespoke projects in the full meaning of the word.

Kler Atelier also develops its own design furniture – produced in modest-sized batches and limited editions which differ vastly from the catalogue pieces.

"I always try to design interiors as if they were a tailored suit. Bespoke. Fitting like a second skin. 100% top quality. These are the interiors – these are the furniture – that I have been tailoring for more than 40 years".

– P. Kler





There are things which present an extraordinary value just in themselves. Genuine leather is a noble material – it requires the best craftsmanship, artistry and mastery. Skilful leather furniture making is a profession known to few. Genuine leather is a noble material – and nobility obliges.

Leather is a living and breathing material which adjusts itself to the ambient temperature, absorbing and releasing moisture. Natural leather does not accumulate dust and it does not absorb smoke. Leather also comes with its specific features, such as unique texture, fine scratches, traces of scars, punctures and other types of marks which came to be before the tanning process and are not flaws, but rather, they testify to the natural origin of the material. A leather-clad armchair or a leather sofa are like good wine. Over the passing years, they take on characteristics which endow them with a unique charm and class.

Selected leathers are divided into groups which compose the Kler leather collection: Prima, Perfetta, Suprema, Nubuck, Elegante, Prescottt.

Quality guaranteed

The leathers which compose the Kler collection are subjected to a thorough validation and control, already in the tannerries. Regardless of these checks, we perform our own tests. We examine the resistance of the coating finish, checking its adhesion, and we confirm the light-resistance of the leather. Our requirements are so stringent because we wish to make sure that the leather-covered furniture that reaches your home bears a guarantee of the highest quality – quality without compromise.



A collection OF PRECIOUS LEATHERS

A collection OF PRECIOUS FABRICS





These fabrics are unparalleled. Soft to the touch, smooth and they fit like a second skin. Those bright and light fabrics evoke the freshness and purity of the morning, the vivid and saturated ones ooze the maturity of a long afternoon, while the thick and fleshy fabrics bestow us with warmth and protection in the evenings, when half-light and silence prevail. There's nothing like a fabric to create a character of an interior.

The wealth of colours, patterns and textures is truly remarkable and it opens up unique opportunities. Modern upholstery fabrics promise beauty and comfort – and the advanced technologies with the use of synthetic microfibers make it possible to achieve greater durability and ease of maintenance. Some of the fabrics are coated with Teflon, which significantly increases their resistance to water absorption and dirt.

Quality guaranteed

We offer a wide range of upholstery fabrics, which have been selected by Kler from a very wide gamut of leading suppliers.

In terms of cleaning ease and resistance to dirt, these fabrics meet all the requirements of European standards, as confirmed during laboratory tests conducted by the manufacturers.

All this is done with one concern in mind: so that the furniture that end up in your home, guarantee the highest quality – a quality without any compromise.

KLER SOFAS AND
ARMCHAIRS



Ramiro



Ramiro



KLER SOFAS AND
ARMCHAIRS



KLER

Oratorio



KLER SOFAS AND
ARMCHAIRS



KLER

KLER SOFAS AND
ARMCHAIRS



Traviata



Figaro Uno



KLER SOFAS AND
ARMCHAIRS



KLER

KLER SOFAS AND
ARMCHAIRS



Figaro Uno / Due



Ottava





KLER SOFAS AND
ARMCHAIRS

KLER

KLER SOFAS AND
ARMCHAIRS



Can-can



Can-can



KLER SOFAS AND
ARMCHAIRS



KLER

KLER SOFAS AND
ARMCHAIRS



KLER

Largo



Largo

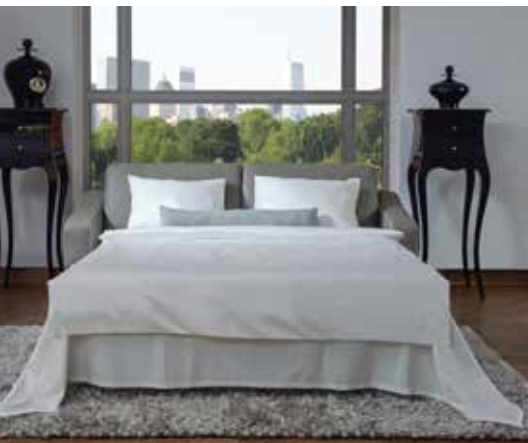

KLER SOFAS AND
ARMCHAIRS



KLER

KLER SOFAS AND
ARMCHAIRS



Swing



Notturmo



KLER SOFAS AND
ARMCHAIRS



KLER

KLER SOFAS AND
ARMCHAIRS



Notturmo



KLER SOFAS AND
ARMCHAIRS



Scherzo



Toccata



KLER SOFAS AND
ARMCHAIRS



KLER

KLER SOFAS AND
ARMCHAIRS



KLER

Charleston



Fantasia



KLER SOFAS AND
ARMCHAIRS



KLER

KLER SOFAS AND
ARMCHAIRS



Mezzo



Orfeo



KLER SOFAS AND
ARMCHAIRS



KLER

KLER SOFAS AND
ARMCHAIRS



Corale



Pausa



Dimensions and technicals ► page 163





KLER SOFAS AND ARMCHAIRS

Dimensions and technicals ► page 163



Violino

KLER

Cornetta



Dimensions and technicals ► page 163





KLER SOFAS AND ARMCHAIRS

Dimensions and technicals ► page 163



Alto

KLER

Tango



Dimensions and technicals ► page 163





KLER SOFAS AND ARMCHAIRS

Dimensions and technicals ► page 163



Tenore

KLER

110 / 111

Habanera



Dimensions and technicals ► page 163





KLER SOFAS AND ARMCHAIRS

Dimensions and technicals ► page 163



Andante

KLER

Vivace



Dimensions and technicals ► page 163





KLER SOFAS AND ARMCHAIRS

Dimensions and technicals ► page 163



Baritono

KLER





cabinets
and cupboards

KLER CABINETS AND
CUPBOARDS



Presto



Musica



KLER CABINETS AND
CUPBOARDS



KLER

KLER CABINETS AND
CUPBOARDS



Canto

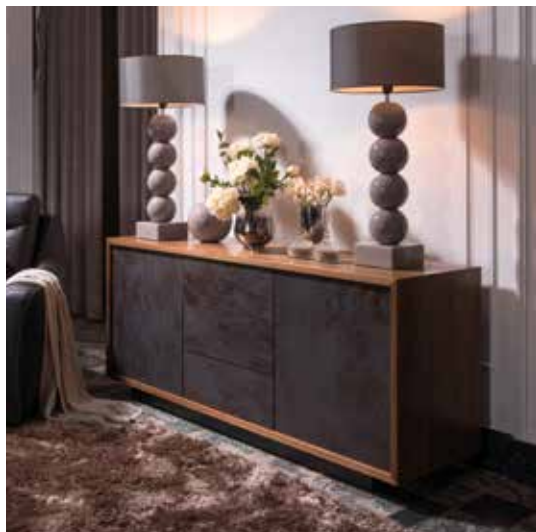

Ornamento





KLER

KLER CABINETS AND
CUPBOARDS



Sonoro



Fresco



KLER CABINETS AND
CUPBOARDS



KLER

KLER CABINETS AND
CUPBOARDS



Ancora







Declare

Home Perfume

velvet

A fragrance composition for the interiors.

A fragrance mix of oriental powders with a complex and subtle sweetness, which passes into a fresh and passionate note of cedar wood.

A discretely composed aroma, lingering in the interior with its delicate muslin mist.

The scent of sensual elegance.



Declare

Home Perfume

satin

A fragrance composition for the interiors.

An exquisite blend of intense floral scents of iris and violet, sensual musk, oriental patchouli and subtle powder notes.

This luminous composition emanates incandescent green aromas - just like early-morning aromatic dew.

The scent of sensual elegance.







A collection OF COFFE TABLES





bedrooms

Balletto



KLER
BEDROOMS



KLER

KLER
BEDROOMS



Euridice



Belcanto



KLER
BEDROOMS



KLER

KLER
BEDROOMS



Semiramide



Turandot



KLER
BEDROOMS



KLER

KLER
BEDROOMS



Otello



E-moll



KLER
BEDROOMS



KLER

KLER
BEDROOMS



KLER

Milonga



LOUNGE SUITES

Bolero (pages 38 / 39)

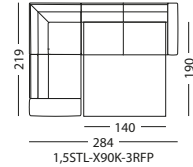
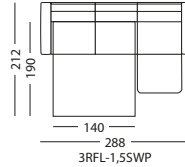
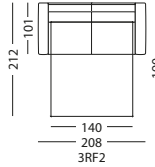
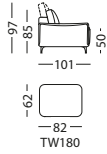

Can-can (pages 78 / 81)

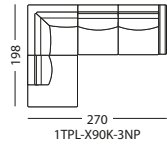
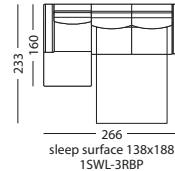
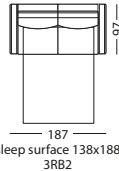
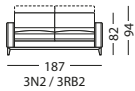
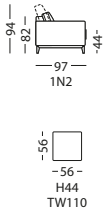

Capriccio (pages 56 / 57)

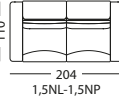
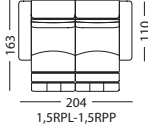
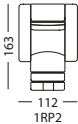
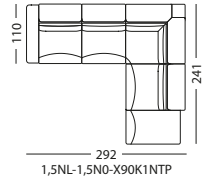
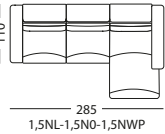
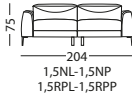

Carmen (pages 40 / 41)

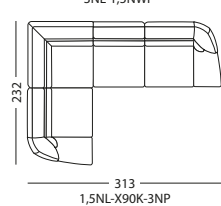
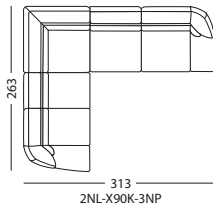
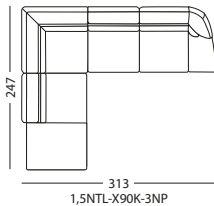
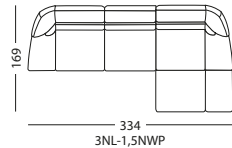
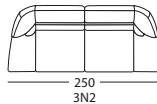
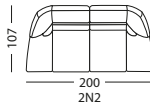
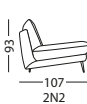

Charleston (pages 96 / 97)

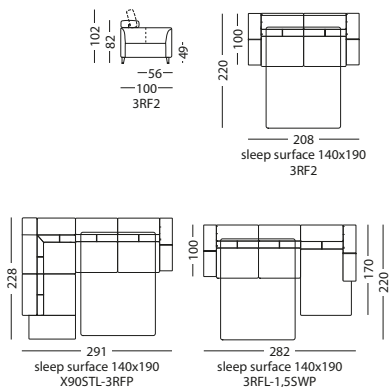

Concerto (pages 42 / 43)

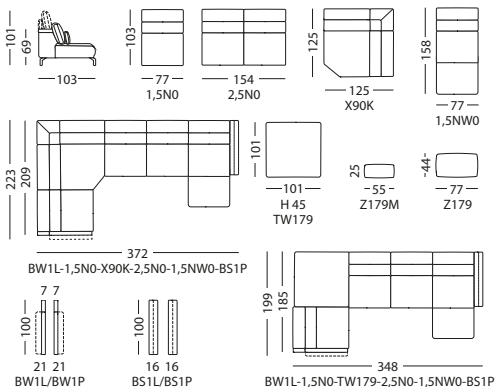

Corale (pages 104 / 105)

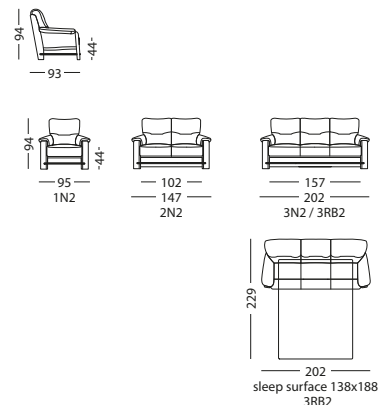

Diva (pages 34 / 35)

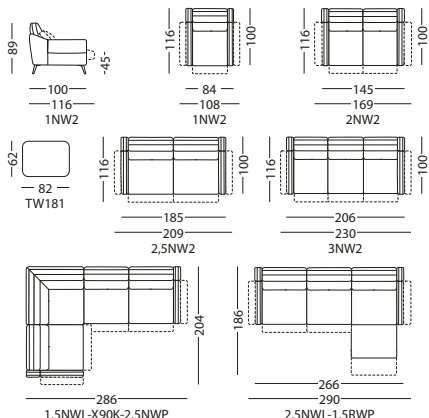

Fantasia (pages 98 / 99)

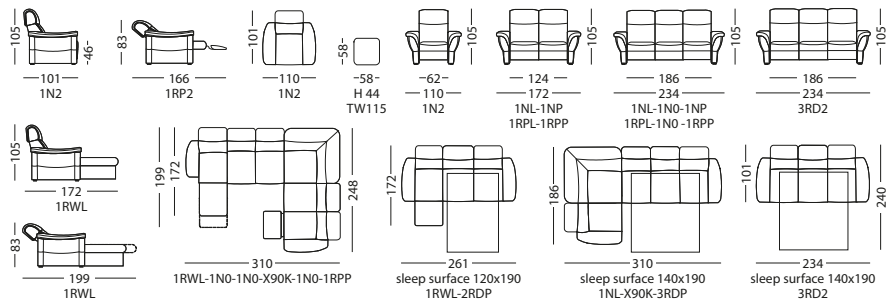

LOUNGE SUITES

Figaro Uno/Due (pages 72 / 75)

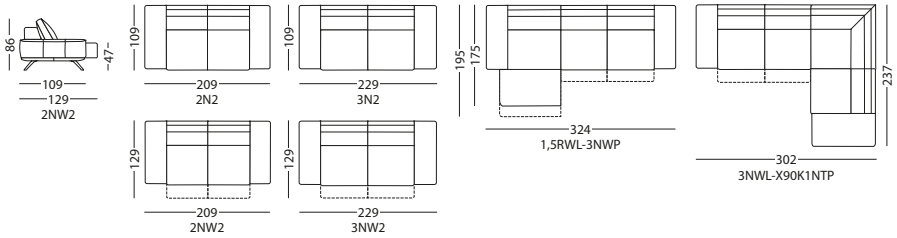

Fuga (pages 52 / 55)

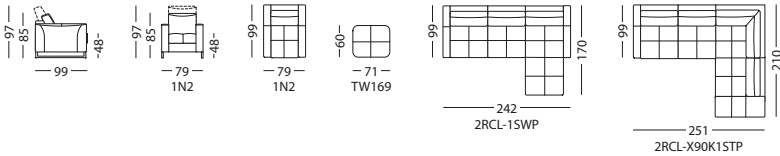

Condoliere (pages 22 / 25)

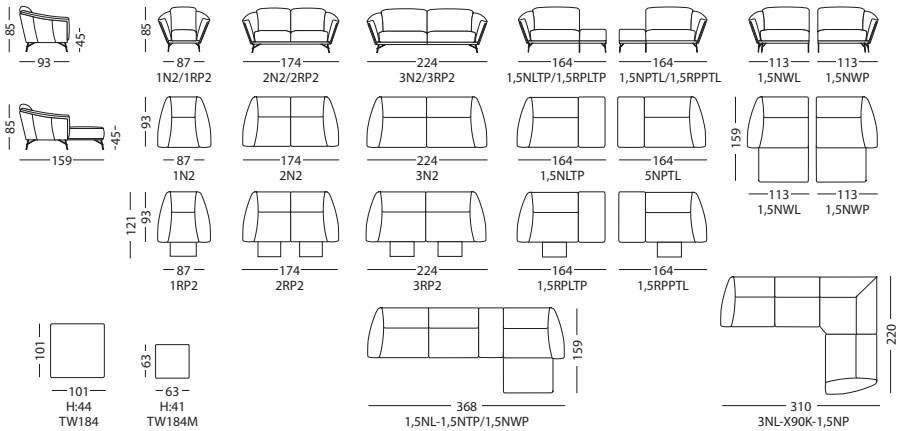

Idillio (pages 6 / 7)

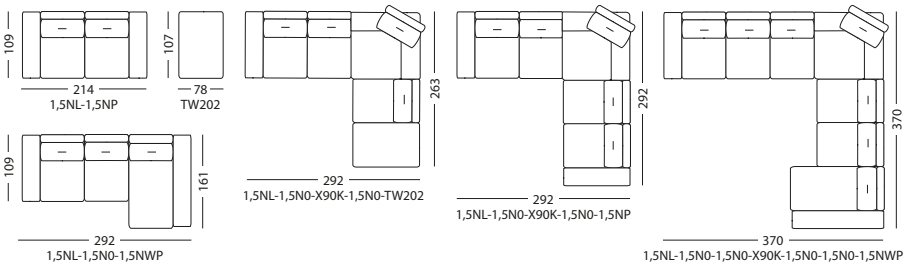

Largo (pages 82 / 85)

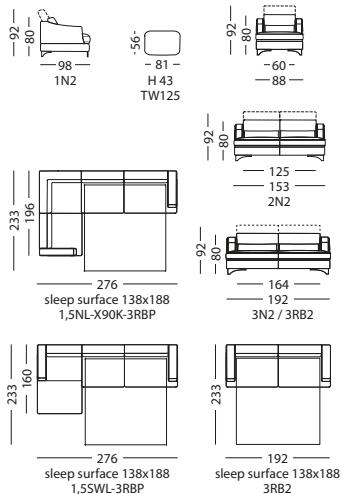

Libretto (pages 8 / 11)

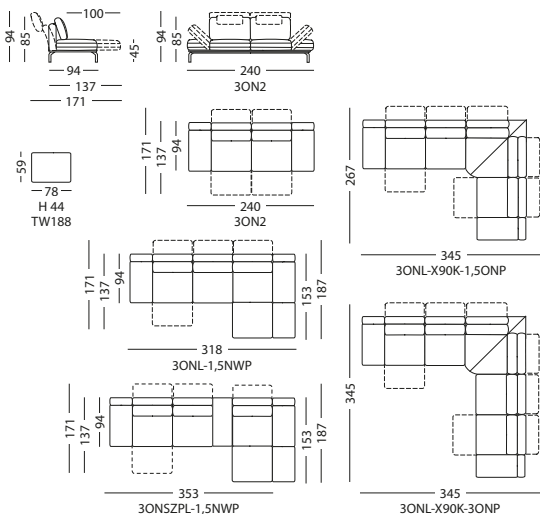

Maestro (pages 36 / 37)

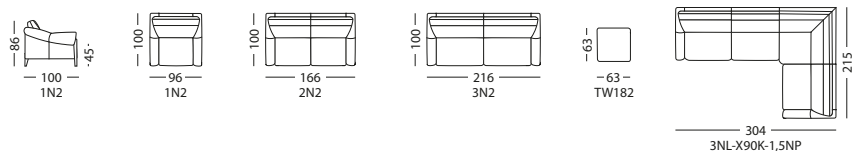

Mezzo (pages 100 / 101)

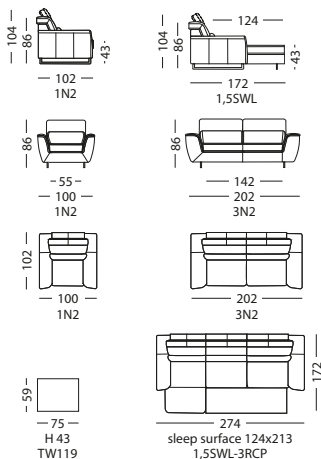

Notturmo (pages 88 / 91)

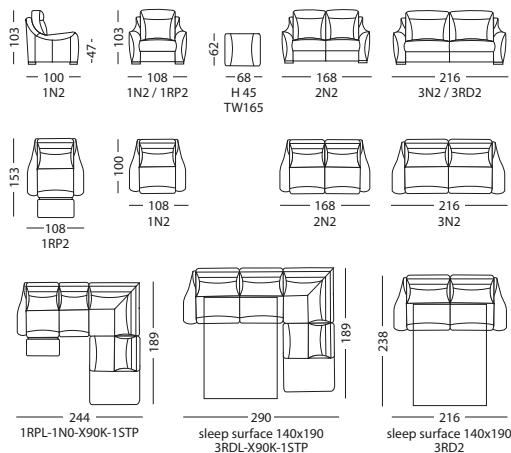

LOUNGE SUITES

Opera (pages 30 / 33)

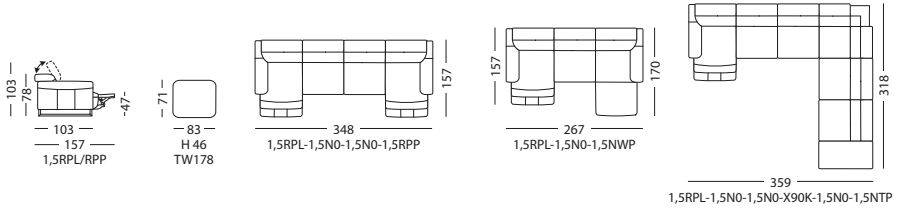

Oratorio (pages 68 / 69)

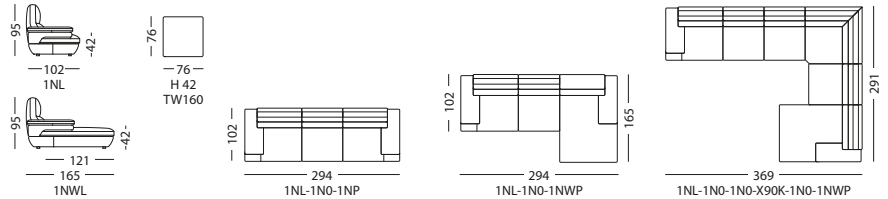

Orfeo (pages 102 / 103)

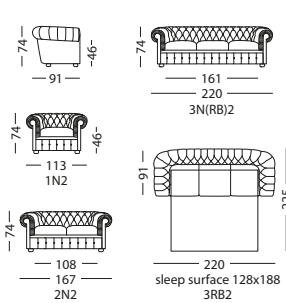

Ottava (pages 76 / 77)

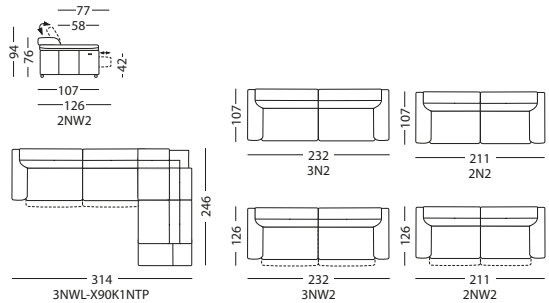

Ramiro (pages 64 / 67)

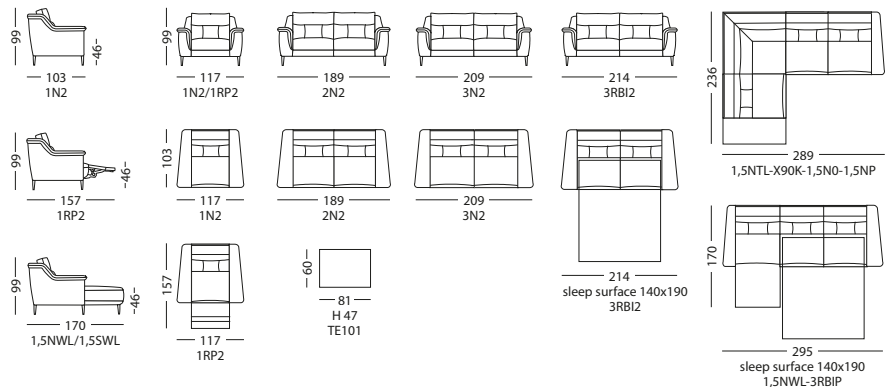

Riposta (pages 50 / 51)

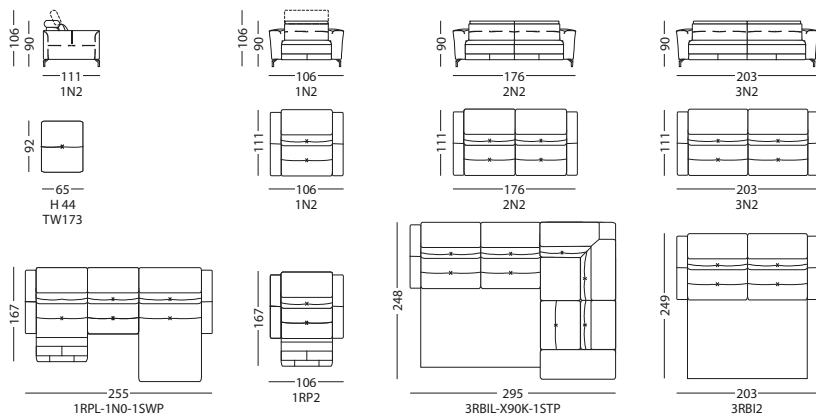

Salterio (pages 12 / 13)

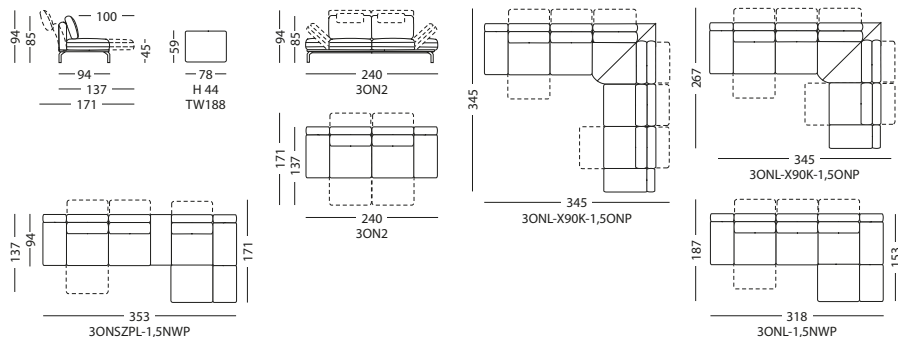

Scaletta (pages 18 / 19)

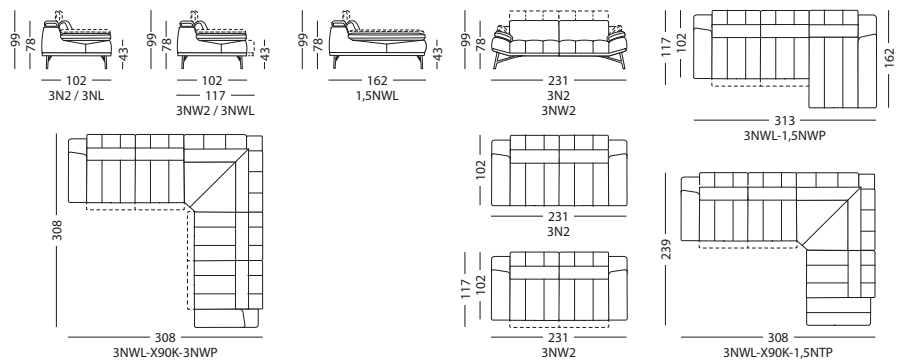

LOUNGE SUITES

Sincopa (pages 44 / 45)

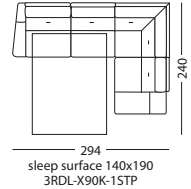
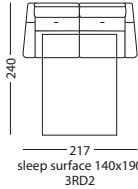
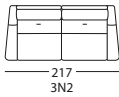
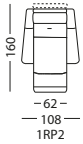
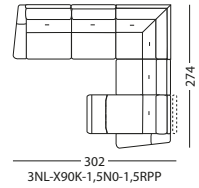
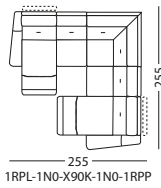
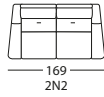

Scherzo (pages 92 / 93)

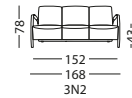
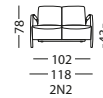

Solfeggio (pages 20 / 21)

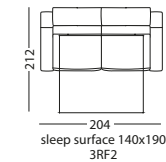
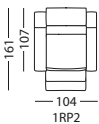
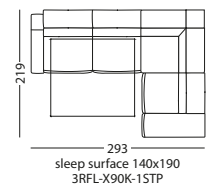
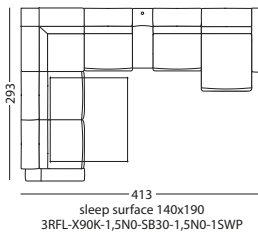
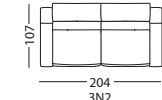
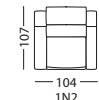
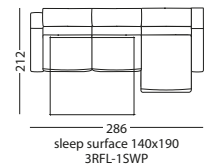
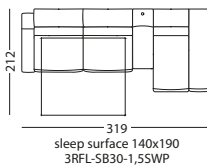
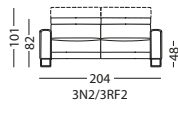
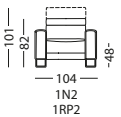
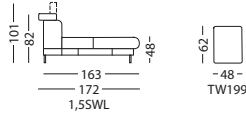
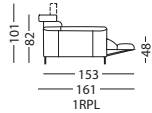
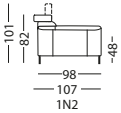

Sonore (pages 14 / 17)

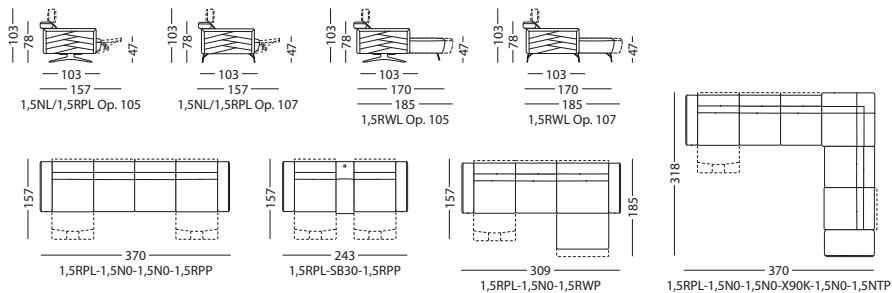

Soprano (pages 46 / 49)

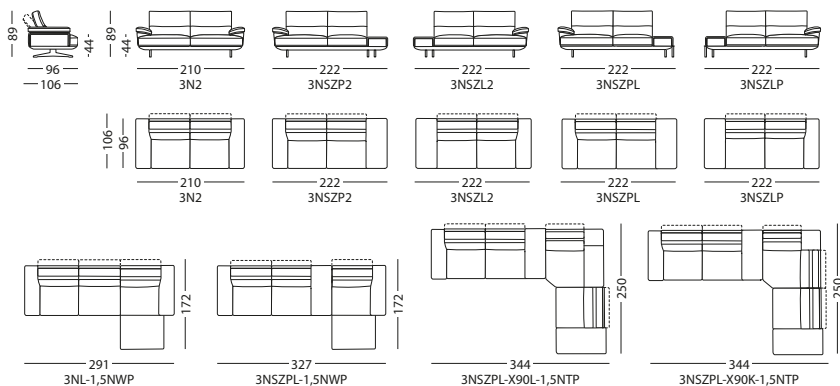

Swing (pages 86 / 87)

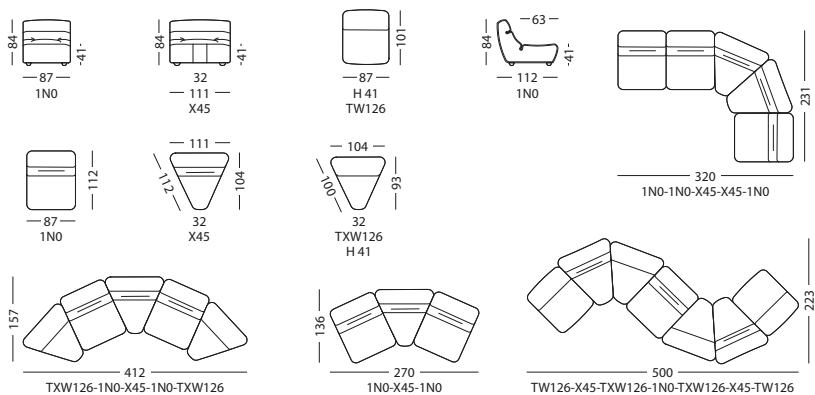

LOUNGE SUITES

Tocatta (pages 94 / 95)

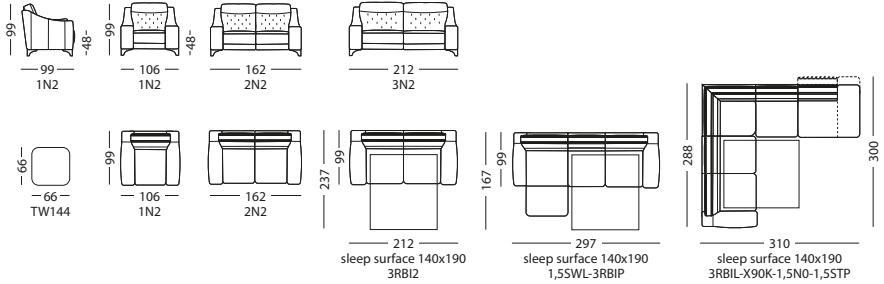

Traviata (pages 70 / 71)

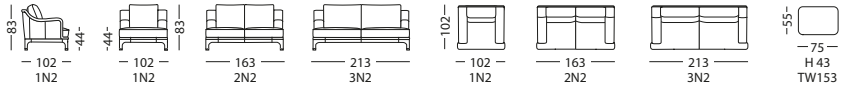

Vocalizzo (page 26 / 29)

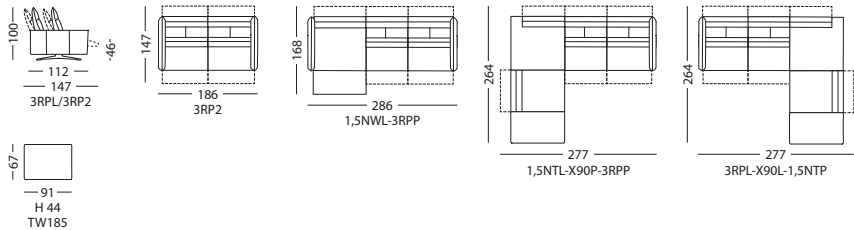

ARMCHAIRS DIMENSIONS / TECHNICALS

Alto (pages 109)

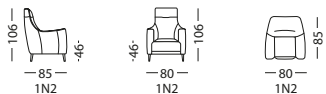

Andante (page 113)

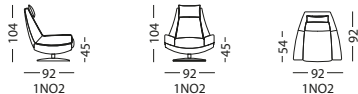

Baritono (page 115)

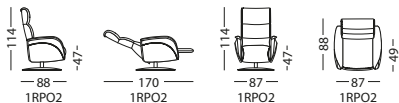

Cornetta (page 108)

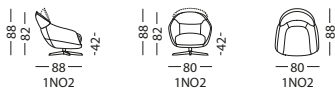

Habanera (page 112)

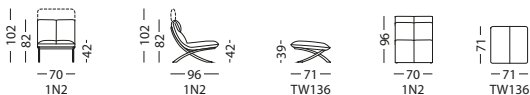

Pausa (page 106)

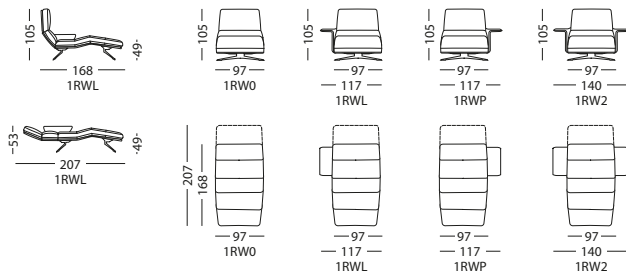

Tango (page 110)

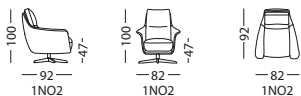

Tenore (pages 111)

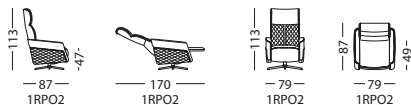

Violino (pages 107)

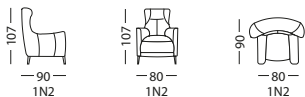

Vivace (page 114)

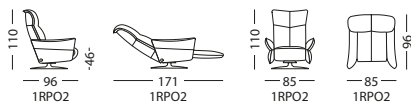

BEDS

Balletto (pages 138 / 139)

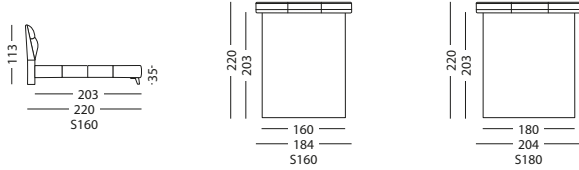

Belcanto (pages 142 / 143)

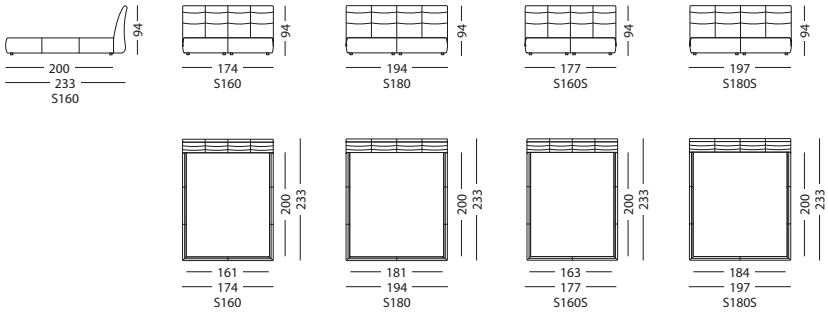

E-moll (pages 150 / 151)

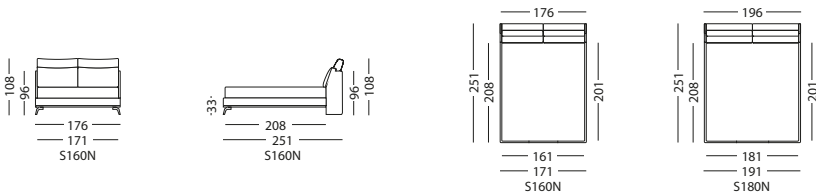

Euridice (pages 140 / 141)

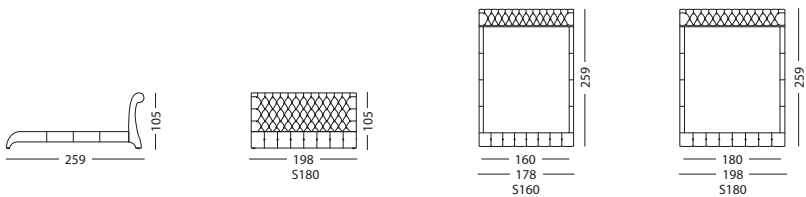

Milonga (pages 152 / 153)

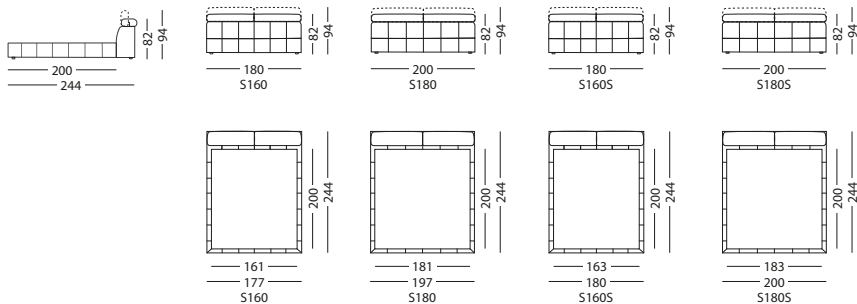

Otello (pages 148 / 149)

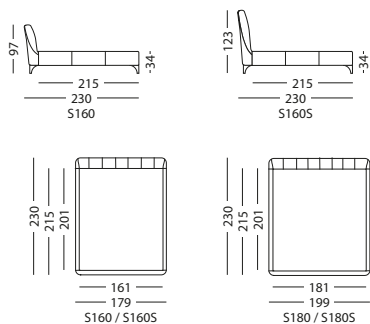

Semiramide (pages 144 / 145)

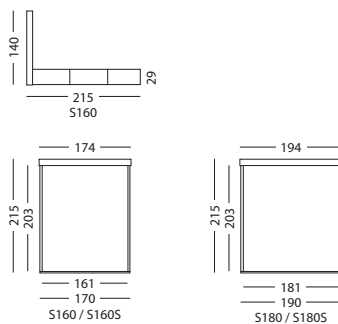

Turandot (pages 146 / 147)

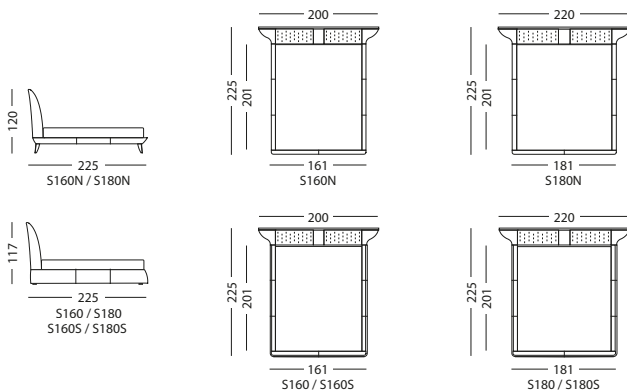

The Kler Standard

Kler – the Company

As a brand, Kler can claim a strong, undisputed presence on the market today, both domestic and international, as well as a significant potential for production and trade. Piotr Kler established it in 1973, and starting from a small craft workshop, he developed it into a well-functioning, modern enterprise. Kler sells furniture all over the world, whether in the corporate chain of show rooms and stores, or by cooperating with partners on a franchise basis. 40 years of steady development and market experience on part of the company is the best guarantee of its credibility and professionalism. The current Kler collection is characterised by the uncompromising quality of the materials used, the precision of workmanship and the classic elegance of design – all of which are already flagship traits of the brand.

Design

The Kler workshops carefully track the trends of contemporary design. Thanks to cooperation with the specially chosen group of domestic designers and an international team of top-notch professionals from Italy and France, we can maintain sensitivity and freshness. The form of our furniture, resulting from the knowledge of the nature of modern interiors, is therefore designed as both fashionable and timeless. And the company, building its market position on the capital of high standards, remains a young and creative brand. Openness on the one hand, and experience on the other – they empower us with the courage to create new objects, which are both beautiful and extremely comfortable.

Kler Showrooms and Stores

You can find the nearest location of our showrooms on our website at www.kler.eu.

Safety Certificate B

The Kler Company has been awarded the Safety Certificate B which confirms that our products, when used in accordance with the principles stipulated by us, do not constitute a threat to life, health, property or the environment. This certificate is issued by the Polish Centre for Testing and Certification – which is an independent, well-known certification body in the European Union.

5 Years' Warranty

Since we have every confidence in the quality that we are offering – we declare that the Kler furniture and objects you purchase are warranted for 60 months. Our warranty covers the workmanship and quality of materials used.

In particular, the five-year warranty covers the wooden and metal frame structure of the upholstered furniture (excluding the movable elements), while the two-year warranty includes the remaining components and materials of these pieces of furniture, followed by the built-in bed on a metal frame and the electric drives of the foldable elements.



Practical Information

Term of Order Execution

Kler furniture are manufactured to order - each customer has the opportunity to influence their final layout, colour and type of upholstery. Our production process makes use of cutting-edge machinery and the latest technologies, but, first and foremost, our furniture are an example of skilful handiwork, which is necessary to obtain the final result of such a high class. Given that each piece of furniture is adapted to customer needs, the average waiting time for your bespoke Kler items is that of 4 weeks.

Cosmetics for furniture care

It goes without saying that all furniture need regular care. However, in order to ensure a good long-term appearance of your furnishings, it is also important to clean and preserve them properly. Kler Care line of furniture cosmetics is a series of specialised formulations developed for cleaning and maintenance of leather, wooden and fabric-upholstered surfaces. When buying our furniture, you will receive the first set of cosmetics free of charge.



A close-up photograph of a bouquet of blue hydrangeas on the left side of the frame. To the right, a dark, textured fabric, possibly a rug or a piece of clothing, is visible. The background is a light, textured surface, likely a wall or a large piece of fabric. The overall mood is calm and sophisticated.

BERLIN

BRATISLAVA

BRUSSELS

CHICAGO

KIEV

MOSCOW

MILAN

PARIS

PRAGUE

TOKYO

TORONTO

VILNIUS

WARSAW

www.kler.eu